

Your Supply Chain Director In China

LEELINE
sourcing

Your Trusted Sourcing Partner In China

Table of Contents

01

Who we are

LeelineSourcing
company quick view

02

Why need us

Check if these are
the problems you
are facing or will
face

03

What we can

Check what we do
to help clients'
business thrive

04

Our value

Check the core
value that clients
get from us

01

Who We Are

Our Company

Leeline Sourcing is an innovative international company with market demand-oriented and supply chain management as its core competency.

We provide value-added services for our clients who are seeking importing services and advice, aiming to maximize clients' profit, while minimize the troubles and problems.

2015

\$35000K+

55+

TOP 500

FOUNDED

ANNUAL PURCHASE
AMOUNT

Country

Supplier

LeelineSourcing Team



Sharline Shaw

CEO

17 years+ years international business experience, aiming to creating long-term social & economic value to both foreign buyer and Chinese suppliers.



Edward Shaw

CO-Founder

13 years+ international business experience, former Marketing director of a China's top 500 manufacturing enterprise.

LeelineSourcing Team



Winnie Wang

Senior Supply Chain Manager

Career: 5 Years sales engineer
experience in manufacture, 7
Years as a buyer work for oversea
clients



Andi Cao

Senior Supply Chain Manager

Career: 3 years of experience as
a sales engineer in
manufacturing, followed by 5
years as a buyer serving overseas
clients.



Daisy Jia

Senior Supply Chain Manager

Career: 8 years of experience as a
buyer for overseas clients,
preceded by 10 years as a sales
engineer in manufacturing.

LeelineSourcing Team



Helen Xie

Senior Supply Chain Manager

Career: With a total of 14 years of experience in the field, 6 of which were spent as a sales engineer in manufacturing and 8 as a buyer for overseas clients.



Irene Li

Senior Marketing Specialist

Career: Having worked as a Brand Marketing Specialist for 3 years, and Experienced in content and branding marketing.



Experts Group

Multi Industry Elites

LeelineSourcing has participated in the development of independent supply chain expert groups for more than 10 years

LEELINE sourcing

Your Trusted Sourcing Partner In China



Experts Group

An organization Composed of
supply chain experts from
different industry



Industry composition of experts

- LED Lighting Equipment
- Vehicles & Spare Parts
- Home Decor & household product
- Office supplies, case & bags and Recreation Products
- Electronics & Household Electrical Appliances
- Consumer Goods
- Building Material
- Textiles & Garments
- Machinery
- Food
- Gifts
- Energy Resources
- Sports, Travel and Recreation Products
- Medicines, Medical Devices and Health Products
- Others

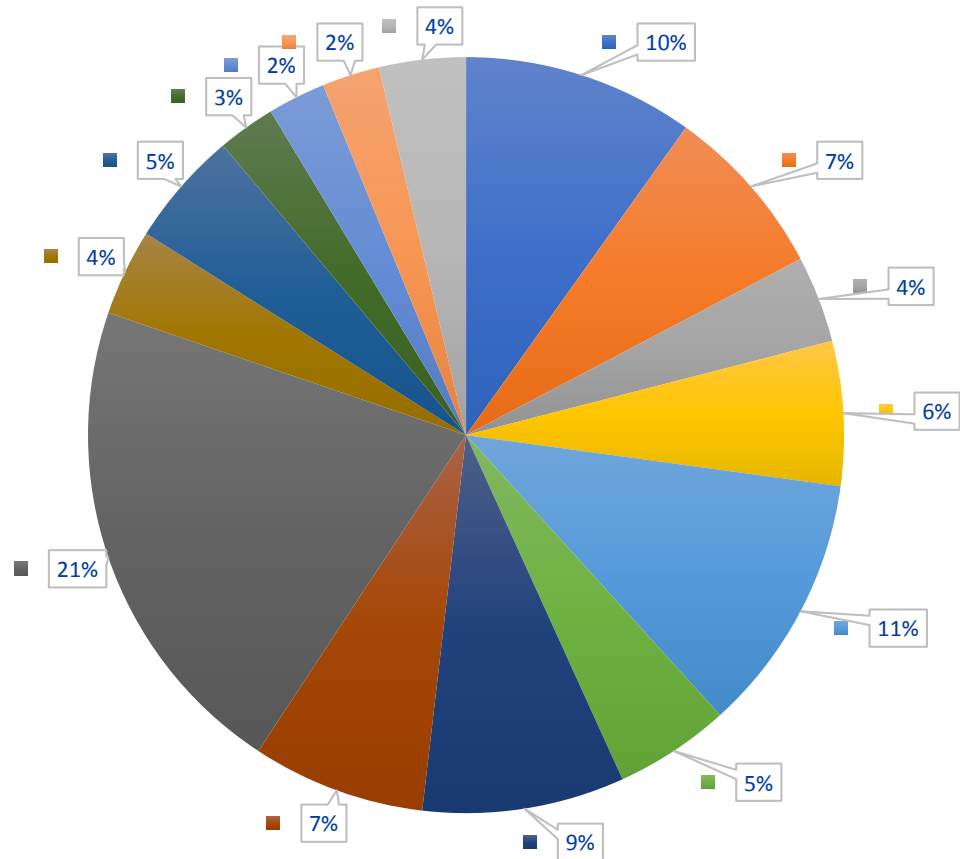

Market composition of experts

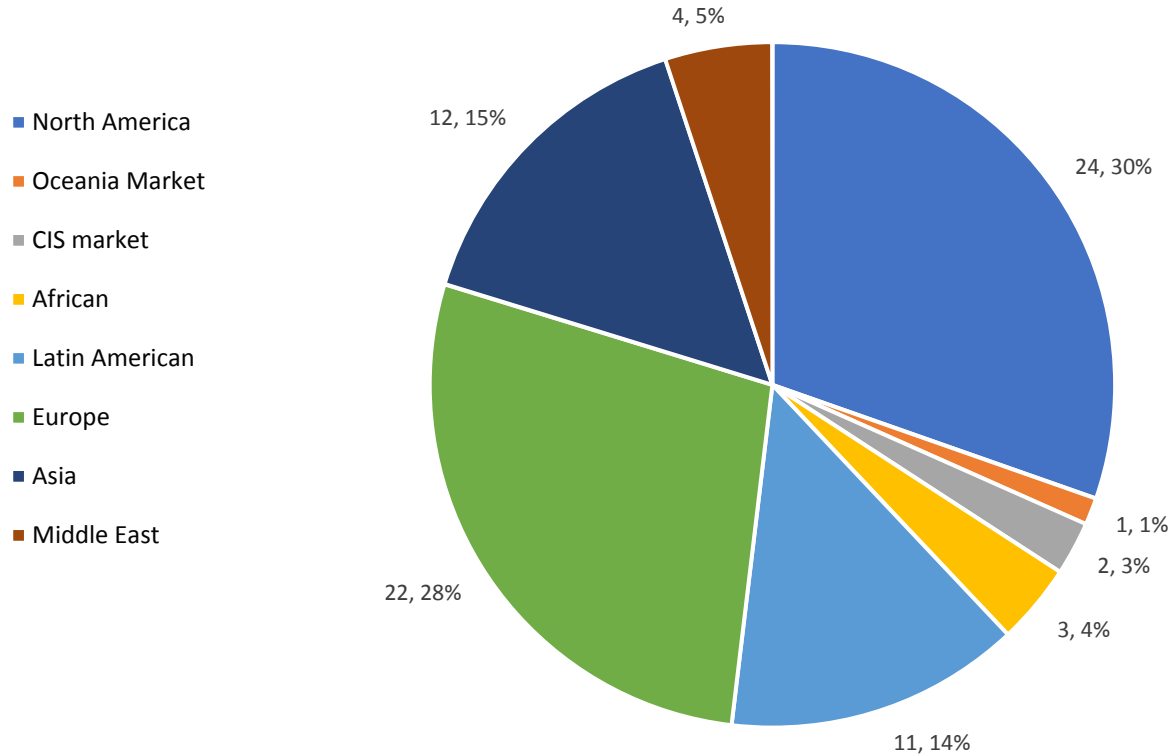

Some of our partners



02

Why Need Us



Time-consuming and Energy sucking supply chain management

- 1- Take time to let suppliers understand different projects
- 2- The goods are different from the samples
- 3 -Unstable delivery seriously affect the sales situation
- 4 - What the factory promises cannot be fulfilled
- 5 - Supplier feedback is inefficient, inconsistent information will appear

LeelineSourci
ng is The
right way to
overcome

03

What We Do

Our services

Supply Chain management From Raw Materials to Order Fulfillment



Supplier sourcing
& order management



Quality control
& Risk
monitoring



Supply chain whole
process optimization



R&D and supplier
chain cost reduction



Trouble Shooting

E-commerce Solution

Supply Chain management From Brand Design to Order
Fulfillment



1688 Sourcing



Amazon FBA Prep
And Shipping



Drop Shipping



Private Label
Branding



Ecommerce Order
Fulfillment



Photography &
Graphic Design

Sourcing Trip



Time 2019

Time 2022

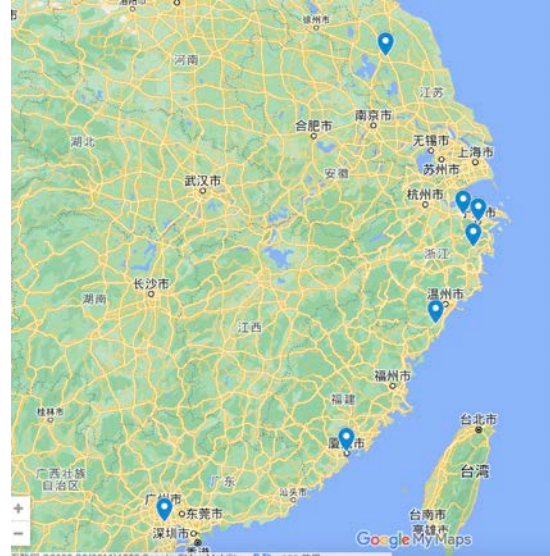
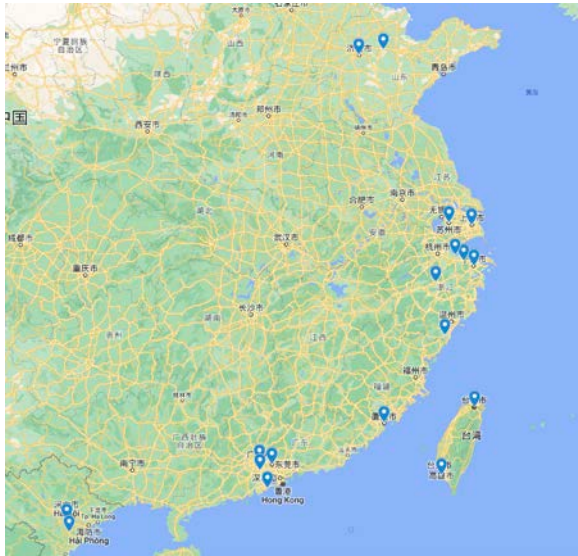

LEELINE
sourcing
Sourcing Partner in China

Supplier Sourcing & Order management

Professional supply market research & report



- 1 Market Situation
- 2 Supplier Situation
- 3 Midea 2018 Mexico line-up
- 4 Price comparison
- 5 Conclusion

CONTENTS

Export quantity of world



Mexican Market structure 2017

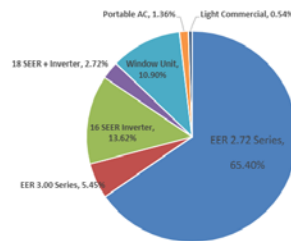

Series	Q'TY (sets)
EER 2.72 Series	1,200,000
EER 3.00 Series	100,000
16 SEER Inverter	250,000
18 SEER + Inverter	50,000
Window Unit	200,000
Portable AC	25,000
Light Commercial	10,000
TOTAL	1,835,000

Comments:

1, DC inverter will be a trend in Mexico & global market, for DC inverter has share 16.34% in 2017, technavio's analysts forecast the global inverter air conditioner market to grow at a CAGR of 12.76% during the period 2016-2020.
2, For EER 3.0, consider cancel it and change to SEER 13, some companies marked EER 3.0 in the actual only reach the EER 2.72, leading to a decline in our Green line competitiveness.

Full report visit:

https://drive.google.com/file/d/1vc_nH_kpLlbx7-UEZq5hK6uXscpjwuUW/view?usp=sharing

Supplier Sourcing & Order management

Report for Supplier & Product

LEELINE sourcing
Your Trusted Sourcing Partner In China

Supplier Report

Zhejiang ABC LAMP CO.LTD
www.abclamp.com
Ningbo, China
Tom
tom@abclamp.com / +86-150xxxxxx

Vendor Type: **Factory** **Booth#** **GILE2021, Hall 4.2 booth 4.2.11**

Exclusivity Available: **NO**

FOB Port: **NINGBO, CHINA** **Manufacturing Speciality:** **Die casting**

No. of Workers: **100-150** **Certifications:** **ELC, DLC, ENEC, CB**

Monthly Production Capacity: **5,000 sets** **Sample Lead Time:** **7 Days**

Payment Terms: **T/T, 30% deposit + 70% against B/L copy.** **Mass Production Lead Time:** **35- 40 Days**

Top 3 Products **Top 3 Export Markets/Channel** **Top 3 Customers**

COB street lamp
high bay light
Garden lamp

North America
German
Spain

XXX
XXX
XXX

Answers to Your Supplemental Questions **Additional Notes**

1. Yes, has street lamp can meet Type III and driver is from Meanwell.
2. Yes, can make new tooling based on your design

This factory has own die casting, with 6 production lines. Have 5 die casting engineer in house.

LEELINE sourcing
Your Trusted Sourcing Partner In China

Sourcing Report

Supplier Name: Zhejiang ABC LAMP CO.LTD
Supplier Address: XXX Industry, NO.2 XXX, XXX Building, Ningbo, Zhejiang, China
Contact Name: TGJ
Title: sales manager
Email: tom@abclamp.com
Website: www.abclamp.com
tel: +86-150xxxx

Vendor Type: Factory
Payment Terms: T/T, 30% deposit + 70% against B/L copy.
Sample Lead time: 7 Days
Production Lead time: 35 -45 Days
Tooling Lead time: 25-35 Days

Item/Model#	Product Name & Description	Product Images	MOQ	Shipping Terms	Quantity	Price (USD)/ Unit	HS Code (Import)
SLC50	COB Led street lamp 50W, outdoor street light with 1 lens, Type III, I beam led driver, IP65 With ENEC, Rohs Cert.		500 pcs	FOB NINGBO	1000 pcs	US\$40.00	8512.10.00.00
SLC100	COB Led street lamp 100W, outdoor street light with 2 lens, Type III, I beam led driver, IP65 With ENEC, Rohs Cert.		500 pcs	FOB NINGBO	800 pcs	US\$70.00	8512.10.00.00
SLC150	COB Led street lamp 150W, outdoor street light with 3 lens, Type III, I beam led driver, IP65 With ENEC, Rohs Cert.		500 pcs	FOB NINGBO	600 pcs	US\$90.00	8512.10.00.00

Full sample report visit:

<https://drive.google.com/file/d/10JUqnKKdQpuJPzHAMxmEDkqswDpXfIBC/view?usp=sharing>

Supplier Sourcing & Order management

Supplier Evaluation & PPAP for order management

生产件批准程序 Production Part Approval Process (PPAP)

back

生产件批准流程用于在供应链中建立对组件供应商及其生产流程的信心，通过证明：The Production Part Approval Process (PPAP) is used in the supply chain to establish confidence in component suppliers and their production processes, by demonstrating that:

“所有客户工程设计记录（图纸）和规格都被供应商正确理解，并且该过程有可能在实际生产运行期间生产始终满足这些要求的产品。”
“...all customer engineering design record (Drawing) and specifications are properly understood by the supplier and that the process has the potential to produce product consistently meeting these requirements during an actual production run at the quoted production rate.”

生产件批准程序要素 PPAP Elements

以下是所有 18 个元素的列表，以及它们的简要说明。
Below is the list of all 18 elements, and a brief description of them.

- 设计记录：图纸复印件。如果客户负责设计，则这是与采购订单 (PO) 一起发送的客户图纸副本。如果供应商负责设计，则这是供应
商发布系统中发布的图纸。
Design Records: A copy of the drawing. If the customer is design responsible this is a copy of customer drawing that is sent together with the Purchase Order (PO). If supplier is design responsible this is a released drawing in supplier's release system.
- 工程变更文件：如果零部件不符合确认图纸设计并且怀疑零部件是否可以使用，则是供供应商偏差请求。
Engineering Change Documents: A copy of the supplier deviation request if parts do not meet the print and it is suspected that the parts can be utilized.
- 客户工程批准：Fetion 对供应商偏差请求的批准。
Customer Engineering Approval: Fetion's approval on a supplier deviation request.

Supplier Evaluation Chart visit:

https://docs.google.com/spreadsheets/d/1z42wfcQEG7sIggFpD-ufiu_eSNcf4vX5/edit?usp=sharing&ouid=103175980339874811280&rtpof=true&sd=true

Full sample PPAP visit:

<https://docs.google.com/spreadsheets/d/1KcluVYweLQ3IUup15fyWIhuP3Kdv-WmuE/edit?usp=sharing&ouid=103175980339874811280&rtpof=true&sd=true>

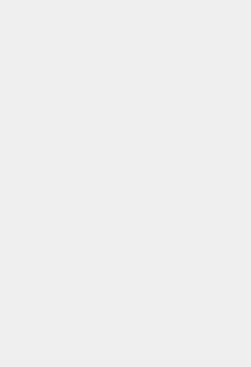

A	B	C	D	E
供应商质量系统评分表				
项目	范围	评级系统	评级说明	分数
1.1	质量体系	质量体系符合基于ISO9000?		4
1.2	质量体系	质量手册是否充分和正确地描述现有的质量体系? 质量手册的更新频率是?		5
1.3	质量体系	工厂是否有为每一个客户设定专门的质量管理体系 (如实施控制等) ?		5
1.4	质量政策	管理是否已开发并制定公布质量政策?		5
1.5	质量目标	该公司是否有书面的质量目标, 为每个顾客, 并通过定期的高级管理人员, 让他们审查?		5
1.6	质量指导	关键的质量指导是什么? 随着时间的推移有没有质量提升改善的证据?		5
1.7	管理评论	工厂的高级管理人员是否会定期对工厂的质量管理体系和质量性能的进行检讨? 这些管理方面的检讨多久会进行一次? 关于不断的改善是否有迹象?		5
1.8	管理评论	关于管理方面的审查记录是否被维护, 并且从之前的管理审查的跟踪, 包括在管理审查的开始和跟踪到结束?		4



Quality control & Risk monitoring

Raw material inspection

Monitoring measures for quality of raw material
Establishing audit procedures
Management measures for supplier

Functionality and reliability testing

- Control of substandard raw materials
- Monitor audit situation
- Making judgments for experiments and statistical analysis
- Validating improvement performance

Manufacture process audit

- Raw material testing
- On-site quality audit
- Provision of improvement report by supplier evaluation

Supplier audit

- Processing of substandard raw materials
- Reviewing of abnormalities in manufacture
- Submitting reports and suggestions
- Continual guidance and monitoring for failures in improvement plans

Part of reference file complete version visit:

<https://drive.google.com/file/d/1Utjkl-KB4m8ioqLNB6-wftZWe5W9GfKq/view?usp=sharing>

Quality control & Risk monitoring

Cost Analysis & Foresee

BY LeelineSourcing 2018/2/8

Full report visit:

<https://drive.google.com/file/d/1te68RfCh2N9gg--FXXqscKQ462i390xK/view?usp=sharing>

The Cost Component

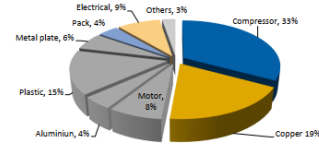

Component	Portion (%)	2017.12	2018.2.8	Inc PCT from 2017 Dec to 2018 Feb(%)	Contribution to unit cost
Compressor	33%			4.00%	1.32%
Copper	23%	53500	52000	-2.80%	-0.64%
Plastic	9%	17200	16900	-1.74%	-0.16%
Metal	7%	3977	3937	-1.01%	-0.07%
Aluminum	5%	14600	14370	-1.58%	-0.08%
Labor Cost	3%			7.49%	0.22%
Exchange Rate/USD:RMB		6.6	6.31	4.60%	4.60%
TOTAL					5.19%

The price of copper



Forecast

SMM forecasts copper prices range RMB 44,000-56,000 in 2018

Product R&D and supplier chain cost reduction



Meeting
with R&D
department



Patent



Product R&D and supplier chain cost reduction

- ★ Case 1: Via product design upgrade optimization, we have helped client **save annual cost 178,500 US dollars**
- ★ Case 2: Supplier price is 30% higher than the budget of client. Without affecting product performance, we have helped customers **achieve a 30% cost reduction** through product optimization.

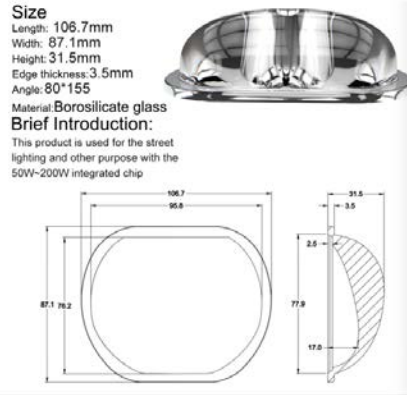

Supply chain whole process optimization

★ Case: Trade tariffs has risen sharply. We have helped customers **reduce import tariffs by 40%** through supply chain optimization.



HST CODE	Rates of Duty	Tariff	Article description	Remarks
4202.92.4500	20%	25%	Travel, sports and similar bags with outer surface of plastic sheeting	List 3
4202.22.1500	15%	25%	Handbags, with or without shoulder straps or without handle, with outer surface of sheeting of plastics	List 3

Trouble Shooting



Case 1: The supplier asked for a 25% price increase on the pretext of rising raw material costs. Through negotiation, we finally set the price increase at 10% of the cost of raw materials, helping customers reduce costs by 15%.



Trouble Shooting

- ★ Case 2: After several rounds of qualified random inspections, the product still had quality problems at the terminal. In the case that the supplier denied the problem, we helped the customer to complete the claim of 80,000 US dollars.
- ★ Case 3: The supplier notified that the delivery date was delayed, and the customer faced the risk of not being able to catch up with the promotional season and canceling the \$160,000 order by the customer's client. We solved the problem by optimizing the production process, and finally shipped on schedule.



04

Our Value



What will you get

We help you grow your business as a long-term partner.

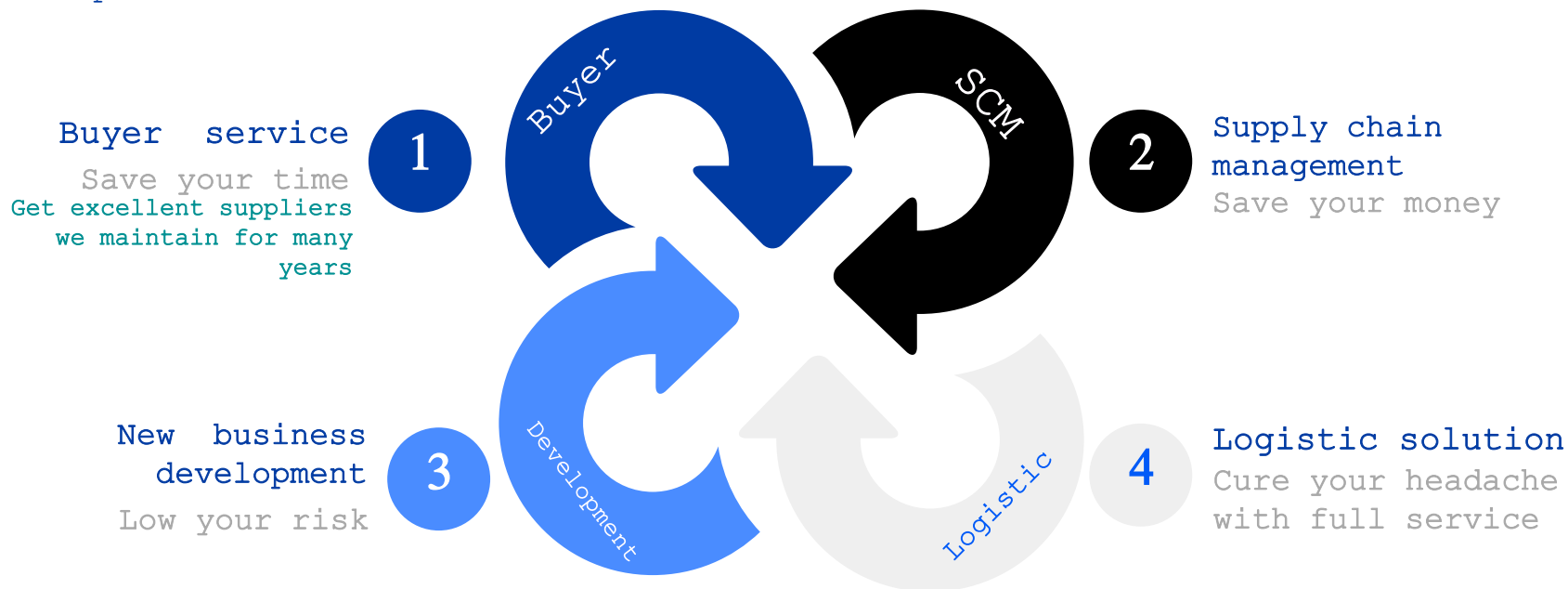

Thanks